

CXD8 白昼信号灯 DAYLIGHT SIGNAL LIGHT

1. 用途 Application

本产品适用于白天和夜晚，船舶之间或船与岸之间通过光信号传递信息。本产品由灯具和电源箱两部分组成。

The product is suitable for signal communication between ship and bank or between ships both in day or night. The product consists of light and power box.

2. 主要技术参数 Main technical parameters :

2.1 灯具技术参数 Technical parameters for light

- 1) 额定电压 Rated Voltage: 24V
- 2) 额定功率 Rated Power: 60W
- 3) 光源 Illuminant: 卤钨灯泡 tungsten halogen lamp
- 4) 白昼能见距离 Range of visibility (daytime) : $\geq 2n.m$
- 5) 发光强度 Luminous intensity: $\geq 60,000cd$
- 6) 使用环境 Atmosphere temperature: $-25^{\circ}C \sim +45^{\circ}C$
- 7) 防护等级 Protection class: IP66

2.2 电源箱技术参数 Technical parameters for power box

输入电源电压 Input voltage: AC100V~240V

输入电源频率 Input frequency: 50Hz/60Hz

输出电压 Output voltage: DC24V

电池电压/容量 Battery voltage/capacity: 24V/6Ah

充电时间 Charging time: $\leq 10h$

放电时间 Discharge time: $\geq 2h$

防护等级 Protection class: IP66

3. 使用方法 Instruction

3.1 灯具的使用 Usage of light

将灯具的插头接电源箱上，打开灯具开关，操作扳手可使灯光明暗变换。在灯具信号为明时，将光束打在屏幕或墙壁上，旋转后盖上的调节旋钮，调整到下表状态方可进行信号的联络。晚上使用时，在前盖上安装减光板，用滚花螺钉固定即可。

CXD8 白昼信号灯 DAYLIGHT SIGNAL LIGHT

Connect the plug with power box, turn on the light, and then adjust the light to be dim or bright by operating the handle.

Let light spot on a screen or the wall when lamp is brightening, then rotate the adjusting knob on the back cover to be down-state so that the lamp can start signal communication. If use at night, please install weakener panel on the front cover and use knurled screw to fix firmly.

距离 Range (m)	3	5	10
宽度 Width (m)	0.38	0.60	1.2

3.2 灯泡的更换 Replacement of bulb

断开电源，旋掉滚花螺钉，取下前盖部件。操作扳手，露出灯泡，旋转后盖上的调节旋钮，当灯头座侧面两孔露出时，用小一字螺丝刀伸进灯头座侧面孔，旋松螺钉，取下旧灯泡。换上新灯泡并旋紧螺钉（注：旋紧螺钉时，力度不可过大）。旋转调节旋钮，将灯泡调至最低。盖好前盖并锁紧。再按“灯具的使用”，将信号灯调节到规定状态。

Cut off power, loosen the knurled screw, and take down the components of the front cover. Operate handle and the bulb will be shown. Rotate the adjusting knob on the back cover until the holes at each side of the bulb holder are shown. Loosen the screw at each side of the bulb holder by small screw driver, remove the old bulb, then replace with a new one and tighten the screws (note: do not tighten the screws with too much strength). Rotate adjusting knob and regulate the bulb to the bottom. Put the front cover and fasten the screw. Adjust the signal lamp to the regular state according to "Usage of light".

3.3 电缆的更换 Replacement of cable

本灯具采用外径为 $\phi 9.5mm$ ， $2 \times 1 mm^2$ 的双芯船用电缆，电缆长度为 5m。断开电源，旋掉固定填料函螺钉，取下填料函、平垫圈、橡胶密封垫；拆下插头和进线圈；旋掉后盖固定螺钉，取下后盖，将原电缆拆下。换上新电缆，并把导线锡焊到开关对应的接线柱上。注意接线必须紧固可靠；将电缆通过手柄，穿过平垫圈、橡胶密封垫，用填料函压紧，旋紧填料函螺钉；装上后盖，用螺钉将后盖固

CXD8 白昼信号灯 DAYLIGHT SIGNAL LIGHT

定；电缆另一端穿过进线圈，将导线锡焊到插头对应的接线柱上，装上插头。

The light adopts five meters of 2×1 mm² marine cable with outer diameter φ9.5mm. Cut off power, loosen the gland screw, take down the gland, flat washer and rubber seal gasket; take apart the plug and coils; loosen the screw in the back cover, remove the back cover and then replace old one with a new cable. Solder the lead wire tightly to the corresponding terminal post of the switch. Put the cable through the handle, flat washer and rubber seal gasket, fix the cable with gland and fasten the gland screw. Put the back cover and fasten the screw. Put the other end of cable through coils, then tin-solder lead wire to the corresponding terminal post of the plug and install the plug.

3.4 瞄准仪的使用 Usage of telescope

用螺钉将瞄准仪固定在灯具的安装架上。注意瞄准仪应与光轴平行。旋转调焦筒，将瞄准仪调整到最佳位置，即所视对象最清晰的位置。使用完毕后，拆下瞄准仪，擦拭干净后用包装袋包好后放入箱内（注意不得划伤前后镜面）。

Fix the telescope with screws on the bracket of the light. The telescope should parallel with the ray axis. Rotate the focus tube and adjust the telescope to the best position, namely in the position that the visibility is clearest. After using, take apart the telescope, clean it and pack it in the box. (Do not scratch the mirror surface)

3.5 灯具与电源箱的使用 Usage of light and power box

开关放电档 Switch discharge: 放电 discharge (蓝色指示灯亮 blue light on)

开关充电档 Switch charge: 充电 charge (充电时绿色指示灯亮，充满时绿色指示灯灭，此时拔掉电源插头。Charging : Green indication light on, full charged: Green indication light off then pull off the plug.)

开关 0 档 Switch 0: 关闭 switch off

把电源线三针母插头插入电源箱的三针公头上旋紧，把电源插头插入电源，把开关打到充电档，绿色指示灯亮，表示在充电。

CXD8 白昼信号灯 DAYLIGHT SIGNAL LIGHT

Insert the 3-pin female plug of power line into the 3-pin male socket, screw tightly. Connect the plug with power source and turn the switch to charge. Then the green indication light will be on, which means charging.

将灯具的四针母插头接到电源箱四针公插头上旋紧，把电源箱开关打到放电档蓝色指示灯亮，表示灯具可以放电了。

Insert the 4-pin female plug of power line into the 4-pin male socket, screw tightly. Turn the switch on power box to discharge and the blue indication light will be on, which means discharging.

不使用时把电源箱开关打到 0 档关闭。

Turn off the switch on power box to 0 when disuse.

电池电量低时，电源箱蜂鸣器报警及红色指示灯亮，此时是提示要充电了。这时把开关拨到 0 档，插上电源插头，把开关拨到充电档，对电源箱充电绿灯亮，电充满后绿灯熄灭。

When the battery is in low power, the power box buzzer will alarm and red indication light will be on, which means the power box needs charging. Turn the switch to 0, connect the plug and then turn the switch to II, the power box will be charging. After finishing charging, the green light will be off.

当电源箱出现故障时黄灯点亮，需对电源箱维修。

When the power box breaks down, the yellow light will be on. Please repair the power box.

4. 灯具与电源箱配件 The accessories of light and power box

1) 反光罩	1 个	Reflector	1 piece.
2) 减光板	1 个	Weakener	1 piece
3) 灯泡	3 个	Bulb	3 pieces
4) 小一字螺丝刀	1 个	Screwdriver	1 piece
5) 瞄准仪	1 个	Telescope	1piece
6) 电源线	1 个	Power line	1piece

CXD8 白昼信号灯 DAYLIGHT SIGNAL LIGHT

5. 维护与保养 Maintenance

5.1 灯具每次使用后，应擦拭干净，存放于外箱内，放于干燥处。

Clean purely the lamp after using, put it in the outer box, store in dry place.

5.2 定期检查灯具各零部件是否有松动或破损，如有松动立即锁紧；如有破损立即更换。

Inspect each component of the light regularly and check whether any looseness or damage. If any looseness, please fasten tightly. If any damage, please make replacement.

5.3 严禁拿着电缆提或拖拉灯具。

Don't carry or drag the light with cable.

5.4 严禁用手触摸灯具的玻璃罩与反光镜。

Don't touch the glass shade and reflector by bare hand.

5.5 电源箱的维护与保养

Maintenance of power box

a. 电源箱的蓄电池可在 0~35℃的环境温度下存放，当蓄电池电压低于 24V 时应立即为蓄电池充电；

The battery of power box can be stored under the temperature 0℃~35℃. The battery should be charged immediately when the voltage is lower than 24V.

b. 电源箱电量不足应立即充电。长期不用时，至少 2-3 个月充一次电。

The power box shall be charged immediately when in shortage of power. If do not use for long time, charge the power box once at interval of 2 to 3 months.

c. 当发现电源箱黄灯亮时，需对电源箱维修。打开底盖，检查各部分导线连接是否可靠，如连接可靠，可更换主板或电池。

When the yellow light is on, please repair the power box. Open the bottom cover and check whether all wires connect firmly. If connect firmly, please change the main board or battery.

d. 除维修外，电源箱不得侧翻、倒置。

CXD8 白昼信号灯 DAYLIGHT SIGNAL LIGHT

Please do not keep the power box convert or turned over except when maintenance .

e. 非专业人员不得打开电源箱。

Please do not open the power box except the professionals .

6. 结构示意图 The dimensions

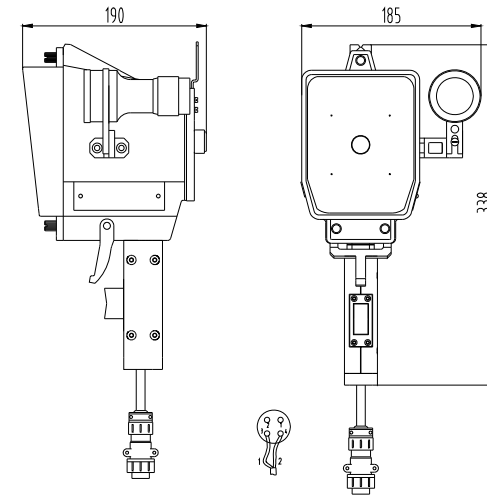

CXD8 灯具 The light

图 1 Picture 1

CXD8 白昼信号灯 DAYLIGHT SIGNAL LIGHT

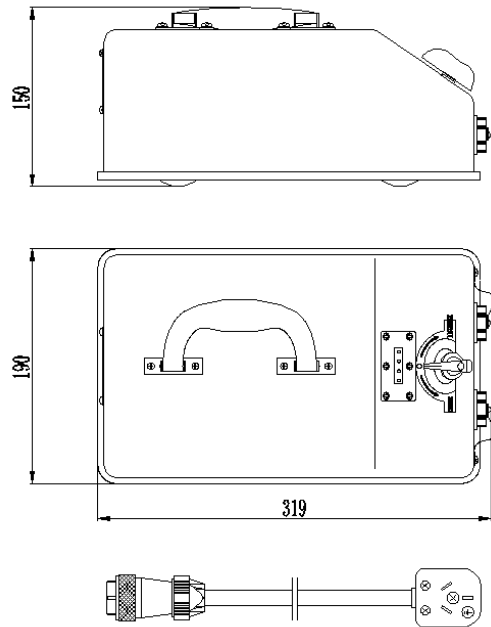

CXD8-DYX 电源箱 Power box 图 2 Picture 2

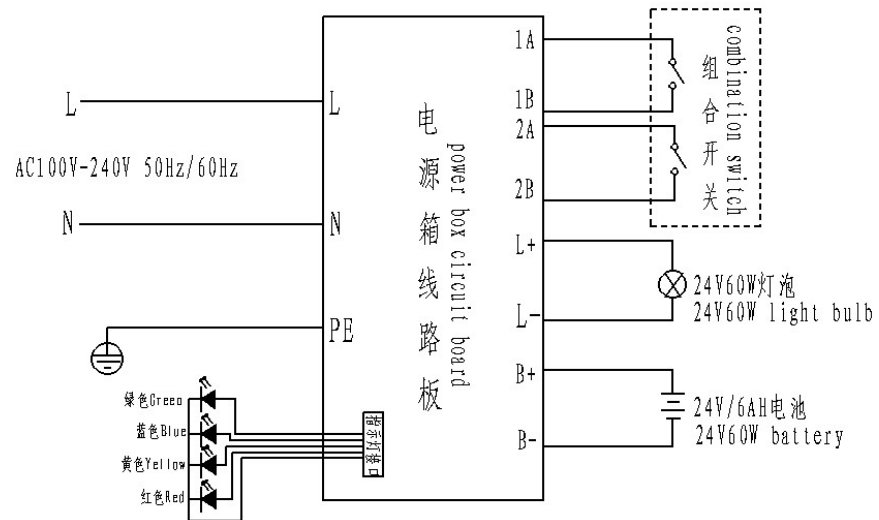

工作原理图 The working diagram 图 3 Picture 3